

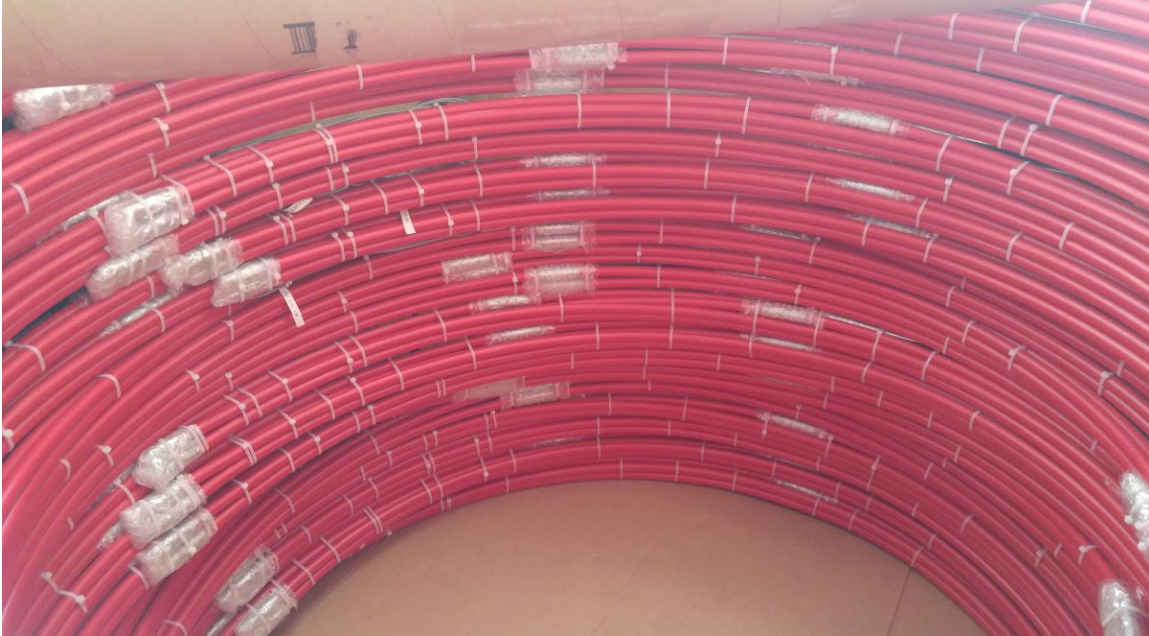

d-EXTO User Manual



YieldPoint Inc.

January 2021

Copyright © 2021 by YieldPoint Inc. The Information contained herein is the exclusive property of YieldPoint Inc., except as otherwise indicated and shall not be reproduced, transmitted, transcribed, stored in a retrieval system, or translated into any human or computer language, in any form or by any means, electronic, mechanical, magnetic, optical, chemical, manual, or otherwise without expressed written authorization from the company. The distribution of this material outside the company may occur only as authorized by the company in writing.

YieldPoint hardware and software products are not designed to be used in the diagnosis and treatment of humans.

Windows™ is a registered trademark of Microsoft Corporation.

Warranty and Service Policy

Product Warranty

YieldPoint Inc., warrants the instruments described in this manual to be free from defects in materials and factory workmanship to the original buyer. This warranty is contingent upon proper use of the equipment, and does not cover equipment that has been modified or has been subjected to abusive physical or electrical stresses. YieldPoint Inc., agrees to repair or replace, at its sole discretion, any instrument that fails to perform as specified within 6 months after date of the original shipment from the factory, or 3 months after the date of installation, whichever date comes first.

Yieldpoint Inc., reserves the right to make substitutions and modifications in the specifications of equipment that do not materially or adversely affect the performance of the equipment.

New equipment may be returned within 30 days of shipment with prior approval. New items which are less than thirty days old after shipment may be returned for credit, less a minimum restocking and testing charge of twenty percent of the list price upon factory approval only, provided the customer pays all shipping and handling charges. Specially ordered, or modified goods, or goods which have been used or have been unpacked, or goods which have been shipped more than thirty days prior are not returnable.

The information contained in this manual is subject to change without notice. YieldPoint Inc. makes no warranty of any kind with regard to this material, including, but not limited to, the implied warranties of merchantability and fitness for a particular purpose. Further, YieldPoint Inc., assumes no responsibility for any errors that may appear in this manual and makes no commitment to update, or keep current, the information contained in this manual.

Service Policy

Units within the warranty period returned for repair, test, and recalibration are serviced at no charge in accordance with the terms of the warranty policy. The Customer pays all transportation and other charges to the factory.

Units out of warranty returned for repair, test, and/or recalibration are handled on a time and material basis. If requested, or if costs exceed 50% of current list price, YieldPoint Inc., advises the customer prior to making the repairs. Such repairs are performed at the customer's expense. Typical test, recalibration, and repairs are 25% of the instrument's current list price. Transportation charges both ways are at the customer's expense.

Please be sure all returns are shipped with the following information included:

1. Your company Name with Billing and Shipping Addresses.
2. A complete description of your problem, or re-calibration data.
3. The contact person at your company, with their telephone and facsimile numbers.
4. Non-Warranty returns additionally need your Purchase Order Number.

Please pack your returned instruments in their original shipping cartons, or in equivalent strong protective shipping cartons.

General Statement

The dEXTO is a fully integrated borehole extensometer that is extremely straightforward to install. This manual outlines a procedure that was developed for long boreholes of small diameter, primarily for mining scenarios, however the installation procedure can be easily modified for a wide range of other applications.

The probe is usually cemented in place and the head of the probe is small enough to be recessed into the collar of the borehole so providing (i) protection against physical damage and (ii) improved thermal stability.

Hole Size

The *d*-EXTO can be installed in 2.25in (57mm) holes and bigger.

Unwrapping the Extensometer.

1. Uncoil the instrument and lay it flat.
2. It is not necessary to wait for the instrument to straighten as the materials used will get is straight right after uncoiling. There is no need to wait to temperature equalization either.
3. Plug the dEXTO into the *d*-READER and take a reading with the instrument uncoiled and relaxed. The instrument will scroll through its anchors. Anchor 1 is closest to the head. Check that all the anchor points are reading within the range of 15 to 25mm.
4. Anchor points read slightly differently when the dEXTO is coiled, the most valuable readings are made with the instrument straightened.
- 5.



Anchor Point

Install the dEXTO

6. Blow all down-holes and in general make sure the holes are as clean as possible.
7. In poor ground insert, a regular (non-instrumented) grout hose to make sure the borehole is viable.
8. Cut a length of grout hole to the appropriate length for the *d*-EXTO. Remember to cut the end of the grout hose at a 60 degree angle to make insertion easier.
9. Securely attach the grout hose to the instrumented end of *d*-EXTO with electrical tape (toe to collar grouting assumed). IMPORTANT: The angled end of the grout hose should be 100mm longer than the *d*-EXTO.
10. Insert into the borehole carefully by pushing on the grout hose. Tape the grout hose to the *d*-EXTO at regular intervals during insertion.
11. If problems occur during insertion remove the borehole extensometer and probe the borehole with a regular 7-wire strand cable to dislodge any loose fragments.
12. Secure the instrument at the collar of the borehole by using expansive foam or burlap cloth.
13. Take a reading with the *d*-READER.

Grouting the cables

14. Use expansive foam or burlap cloth to seal collar of hole if the water/cement ratio is greater than 0.38.
15. Grout the cables with a 0.35 - 0.38 w/c ratio Portland cement grout. Other grouts such as mortar and epoxy resin can also be used.
16. Under no circumstances use a grout greater than 0.40 w:c ratio.

List of items that must be accounted for before installation

1. Boreholes of the proper length and diameter must have been prepared and cleaned.
2. A grouting pump must be available, with suitable power to push the grout all the way into the borehole.
3. Cement and water must be available, in quantities sufficient to fill all boreholes.
4. Burlap and wood wedges must be available.
5. Grout tubes of appropriate lengths, and tape to tie to the extensometers, must be available.
6. All YieldPoint instruments to be installed must be available at the site at the proper level. Extensometers must be uncoiled and laid to rest and straighten.
7. A YieldPoint dREADER readout unit with its 9V battery must be available to check all instruments before and after installation.
8. When instrumented bolts must be spun in resin or grout, the appropriate drills must be made available.

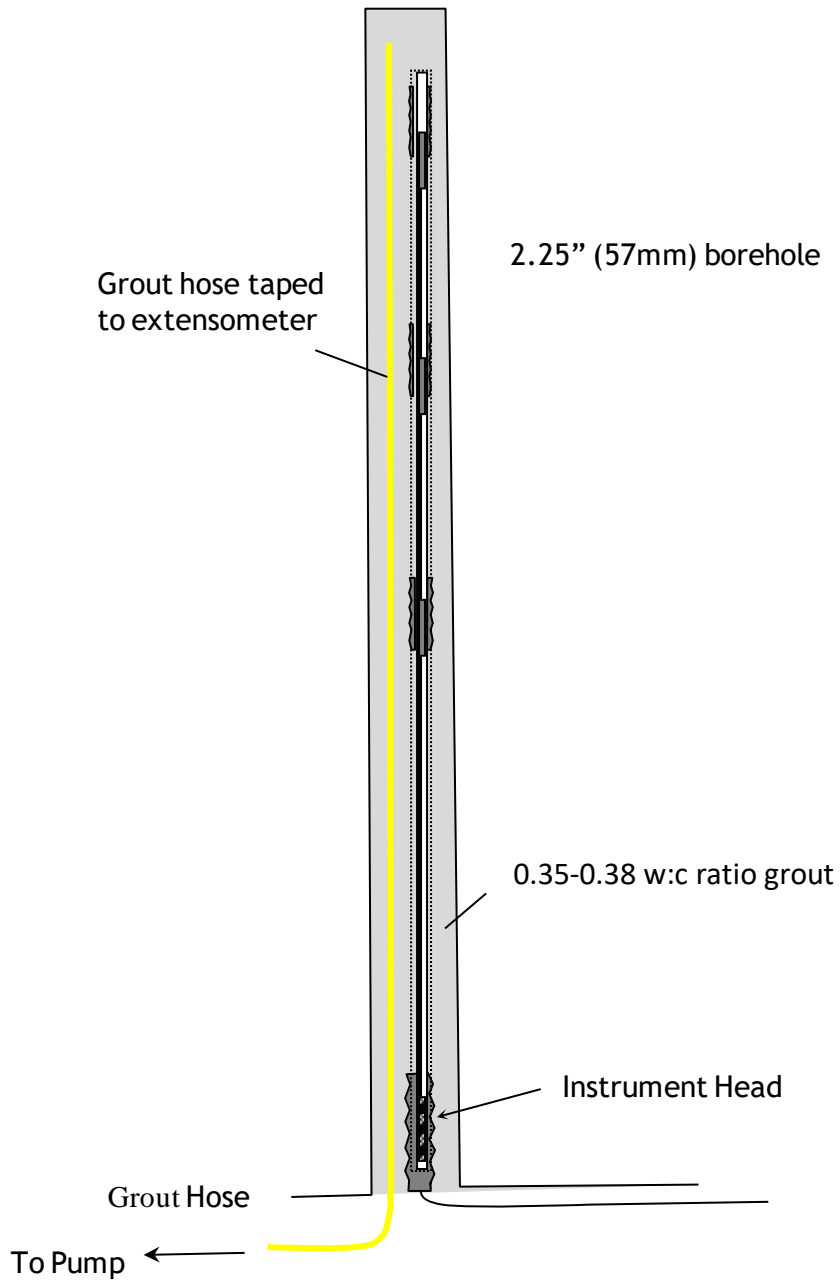
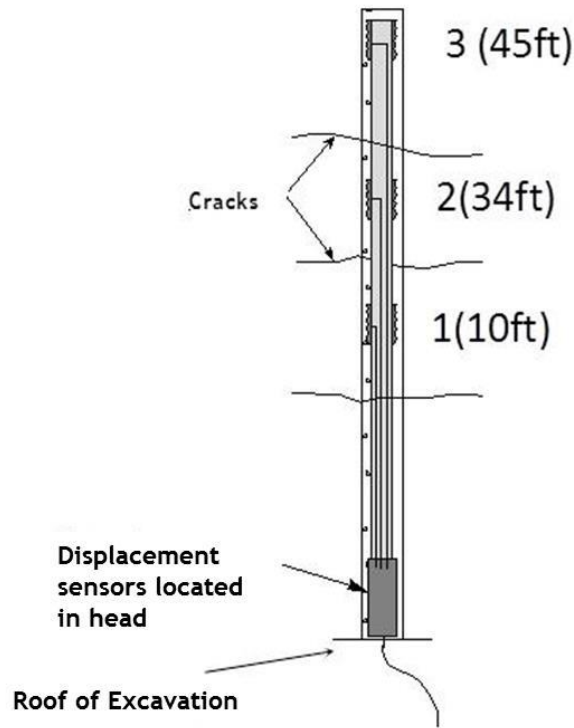

Figure 1: Fully installed *d-EXTO* in uphole.

DATA INTERPRETATION

Assume we have a 3 point extensometer with anchors at 10ft, 34ft and 45ft from the roof of the excavation.



Some hypothetical readings are shown in the following table. Notice that the readings are larger for the more distant anchors even though we intuitively know these points have physically moved less (i.e. things appear the wrong way around).

Anchor	T=0	T=7days	T=14 days
3 (45ft)	13.35	17.65	21.65
2 (34ft)	16.71	20.23	23.75
1 (10ft)	24.34	24.65	25.13
Roof	N/A	N/A	N/A

RAW EXTENSOMETER DATA

Then referencing the displacements to their values at t=0, we obtain:

Anchor	T=0	T=7days	T=14 days
3 (45ft)	0.00	4.30	8.30
2 (34ft)	0.00	3.52	7.04
1 (10ft)	0.00	0.31	0.79
Roof	N/A	N/A	N/A

TIME REFERENCED EXTENSOMETER DATA

Now we need to “invert” the time-referenced extensometer data based on the fact that Anchor 3 at 45ft has moved least. This results in:

Anchor	T=0	T=7days	T=14 days
3 (45ft)	0.00	0.00	0.00
2 (34ft)	0.00	0.78	1.26
1 (10ft)	0.00	3.99	7.51
Roof	0.00	4.30	8.30

SPATIALLY INVERTED EXTENSOMETER DATA

The inversion expression is simply:

$$\text{inverted displacement (10ft)} = \text{displacement (45ft new ref)} - \text{displacement(10ft)}$$

Notice that

$$\text{Inverted displacement (Roof)} = \text{displacement (45ft)}$$

Since this is the relative displacement between the 45ft anchor(new reference) and the roof.

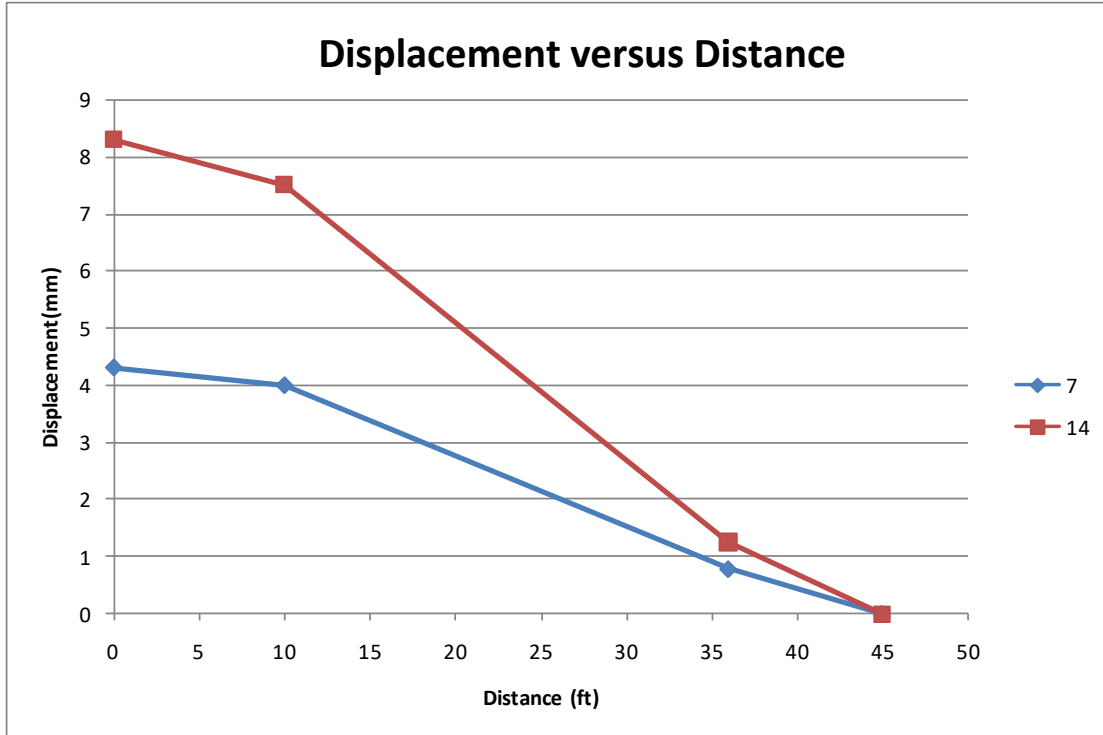

An Excel spreadsheet can be developed and spatial plots can be generated with each line representing a snapshot for a given date (7 and 14 days in this case).

The slope of the 2 plots is the average strain between the anchor points. Notice this is greater between the 10ft and 34ft anchor than between 0 and 10ft. The strain (in microstrain) can be calculated from:

$$\text{Average strain (10-36)} = 100000(\text{Spat Ref. Disp (10ft)} - \text{Spat Ref Disp(34ft)}) / ((34-10) * 304.8)$$

304.8 being the conversion factor between ft and mm. This gives the results presented in the table below:

	Interval 1	Interval 2	Interval 3

	Roof-> 10	10-> 34	34->45
Location (ft)	5	23	40.5
0 days	0	0	0
7 days	101.706	405.0575	284.3395
14 days	259.1864	788.6634	459.3176

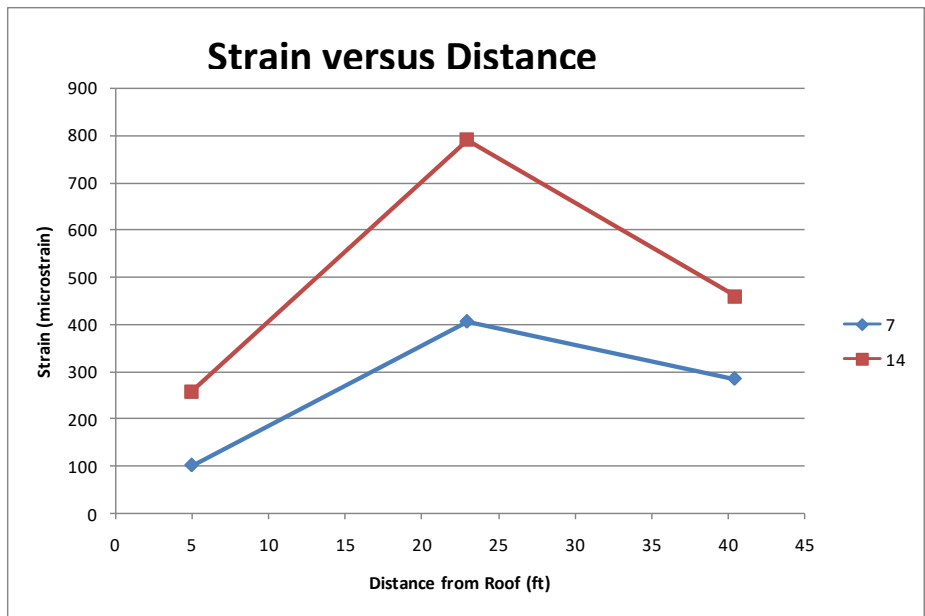

Notice that the strain values are plotted midway between the anchor points.

Strain is often a good indicator of crack density and indicates whether the deformation is truly distributed or localized at specific structures.